



US006995895B2

(12) **United States Patent**
Greywall

(10) **Patent No.:** **US 6,995,895 B2**

(45) **Date of Patent:** **Feb. 7, 2006**

(54) **MEMS ACTUATOR FOR PISTON AND TILT MOTION**

6,201,631 B1	3/2001	Greywall	
6,283,601 B1	9/2001	Hagelin et al.	
6,384,952 B1	5/2002	Clark et al.	
6,497,141 B1 *	12/2002	Turner et al.	73/105
6,771,001 B2 *	8/2004	Mao et al.	310/309

(75) Inventor: **Dennis S. Greywall**, Whitehouse Station, NJ (US)

* cited by examiner

(73) Assignee: **Lucent Technologies Inc.**, Murray Hill, NJ (US)

Primary Examiner—Scott J. Sugarman
Assistant Examiner—Richard Hanig

(*) Notice: Subject to any disclaimer, the term of this patent is extended or adjusted under 35 U.S.C. 154(b) by 29 days.

(57) **ABSTRACT**

(21) Appl. No.: **10/772,847**

A MEMS device having a spring structure formed by two flexible beams attached between a substrate and a movable bar. When non-end sections of the beams are pulled in opposite directions, the beam ends attached to the movable bar pull that bar toward the substrate, thereby transforming in-plane motion of the non-end sections into out-of-plane motion of the movable bar. When the non-end sections are displaced symmetrically, the movable bar translates toward the substrate. Alternatively, when the non-end sections are displaced non-symmetrically, the movable bar rotates with respect to the substrate. In one embodiment, each flexible beam is attached to a comb-shaped portion of a motion actuator, which has two such portions, each portion interleaved with the other portion and adapted to move with respect to the substrate and that other portion. When a voltage differential is applied between the portions, they move substantially parallel to the substrate, thereby deforming the beams and translating/rotating the movable bar.

(22) Filed: **Feb. 5, 2004**

(65) **Prior Publication Data**

US 2005/0174624 A1 Aug. 11, 2005

(51) **Int. Cl.**
G02B 26/00 (2006.01)

(52) **U.S. Cl.** **359/290**; 310/309

(58) **Field of Classification Search** 359/290, 359/291, 198, 199, 201, 202, 203, 214; 310/309
See application file for complete search history.

(56) **References Cited**

U.S. PATENT DOCUMENTS

5,501,893 A	3/1996	Laermer et al.
5,629,790 A	5/1997	Neukermans et al.
5,745,278 A	4/1998	La Fiandra

29 Claims, 12 Drawing Sheets

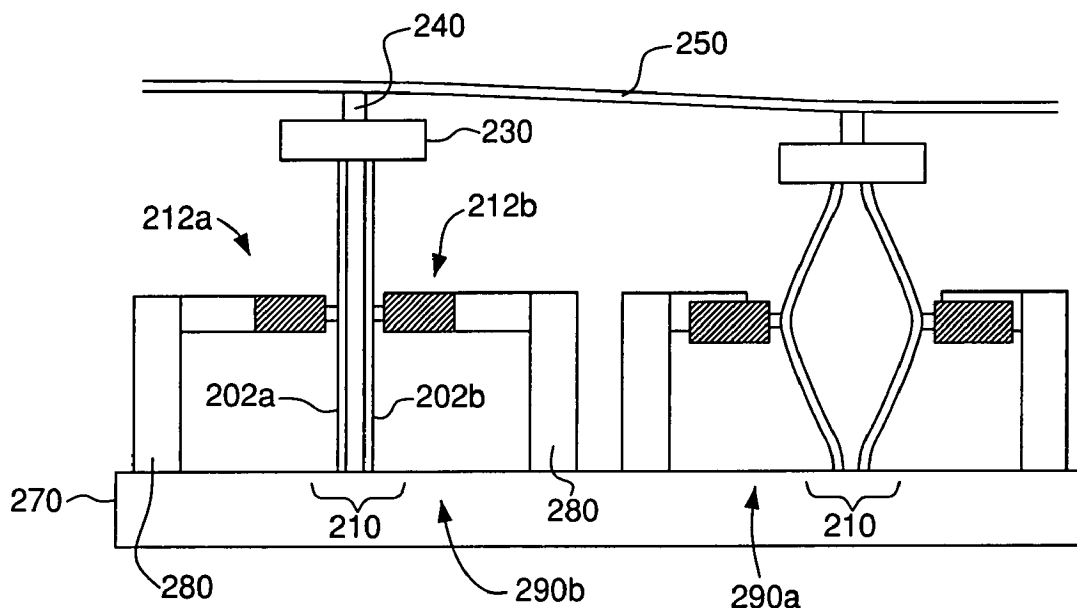

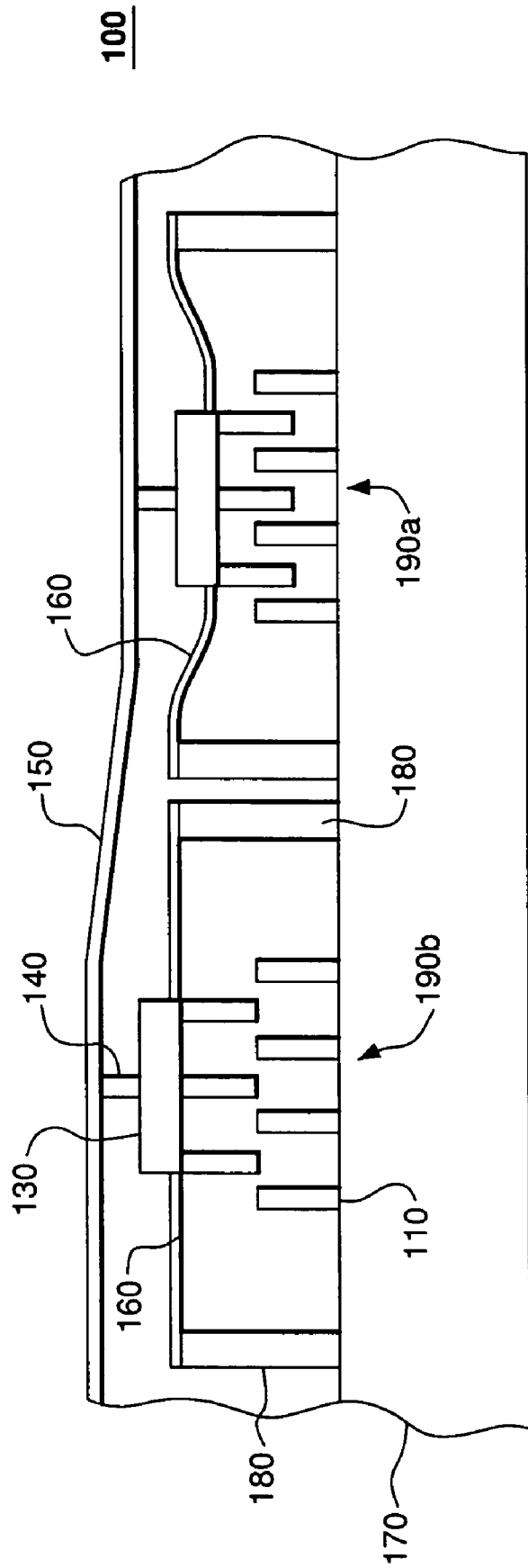

FIG. 1
(Prior Art)

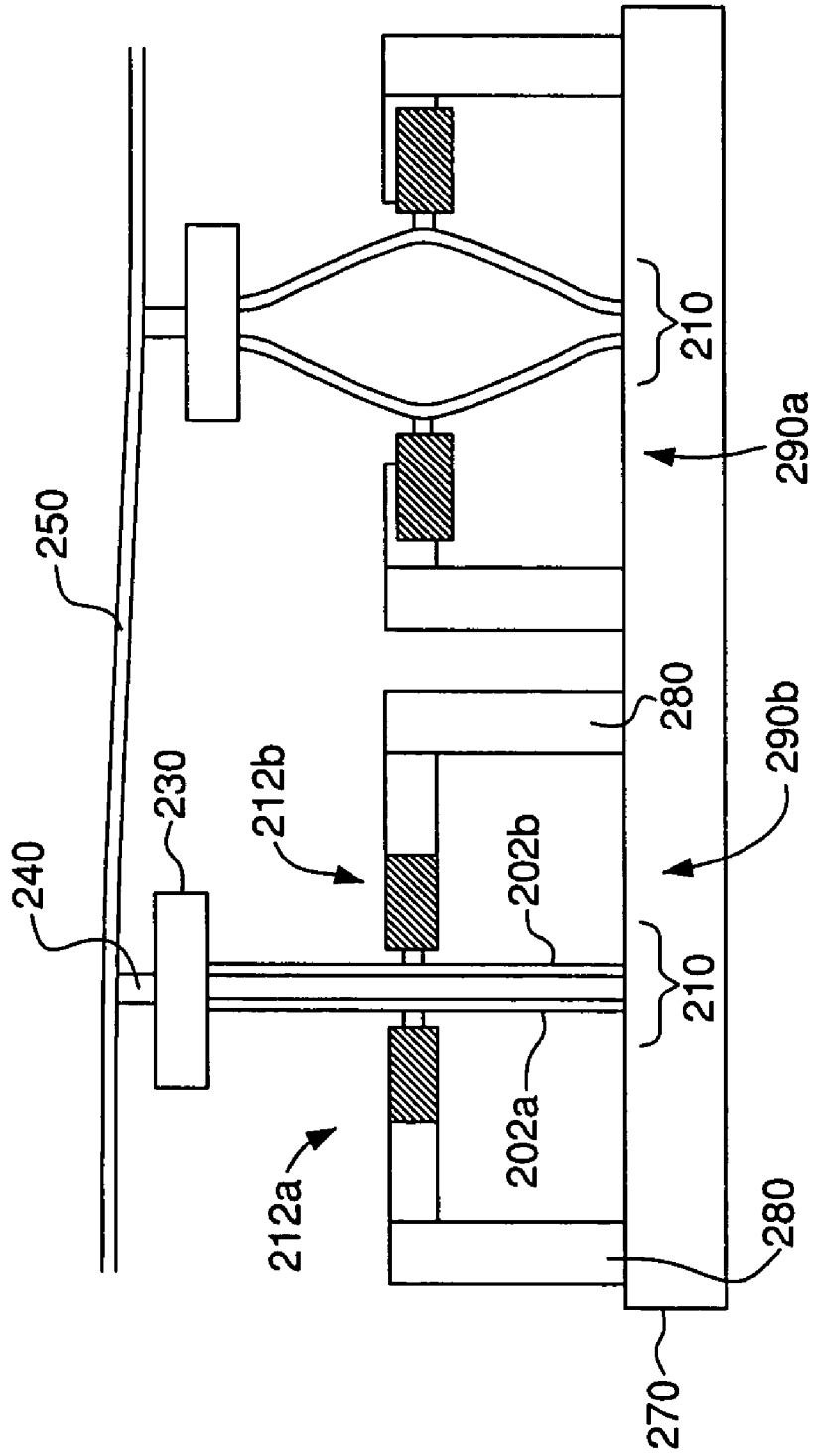

FIG. 2

200

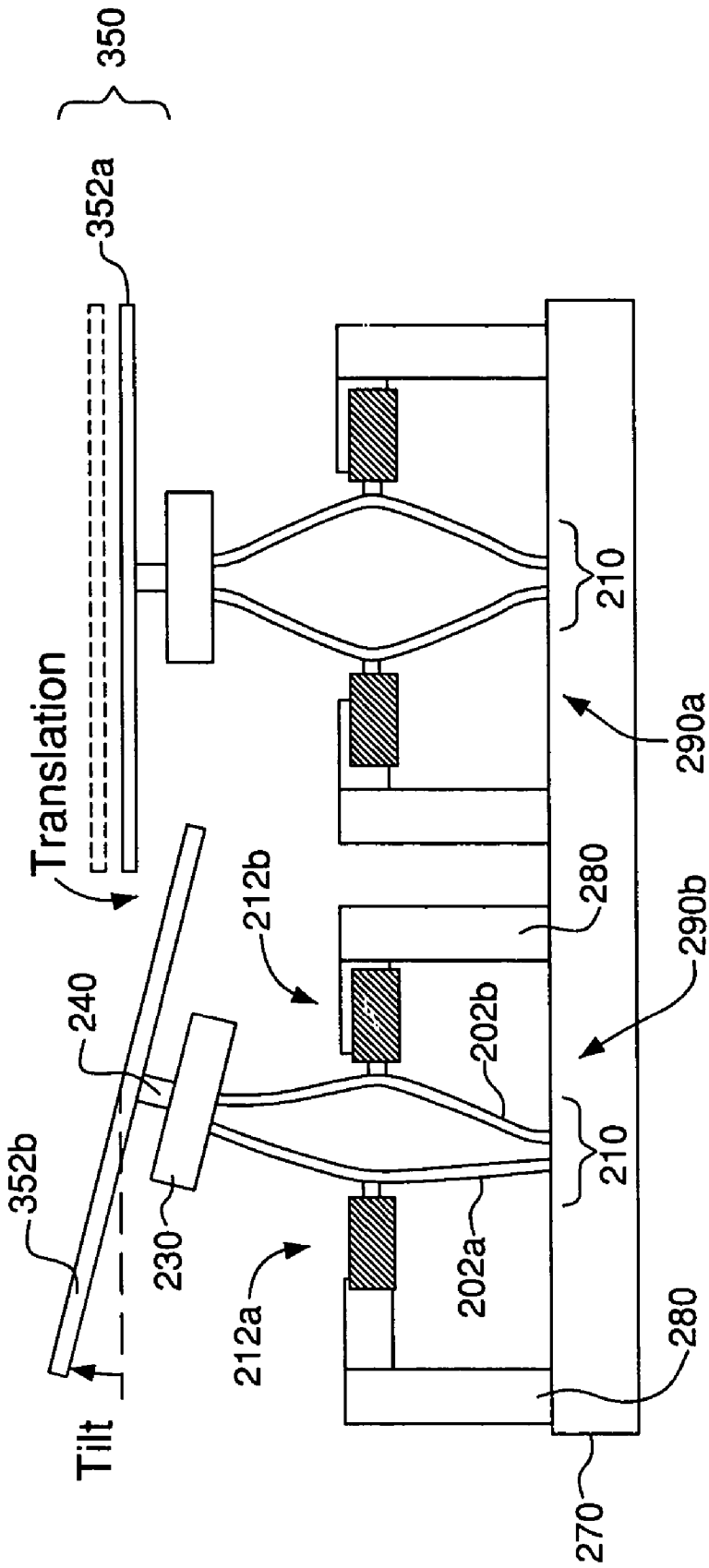

FIG. 3

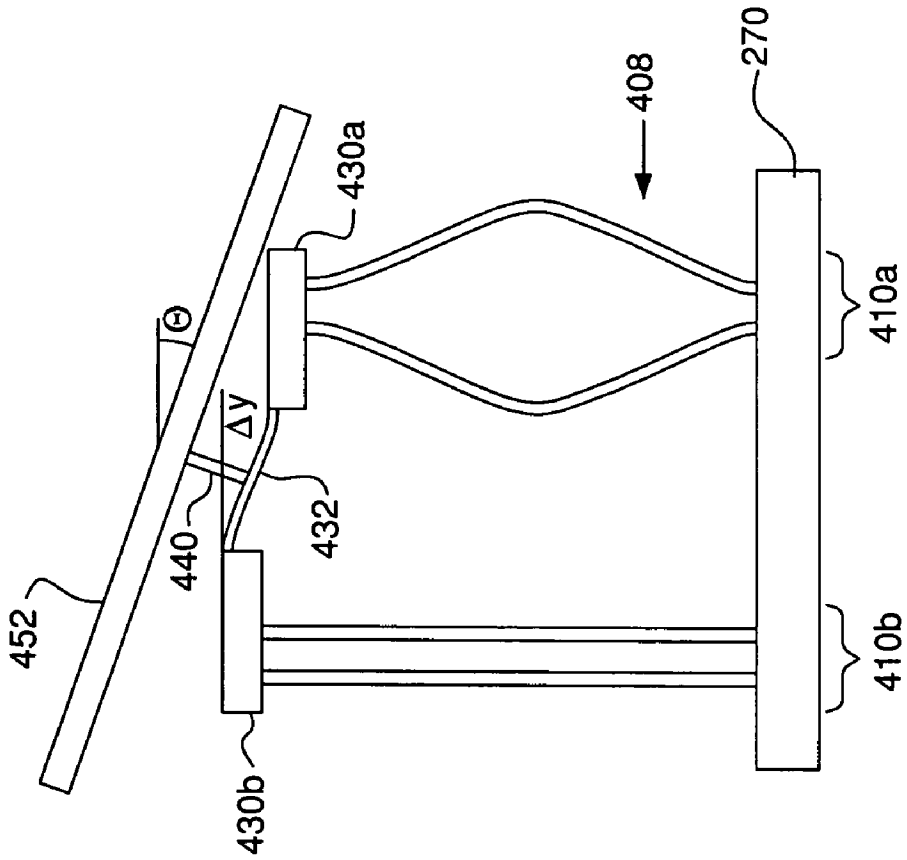

FIG. 4

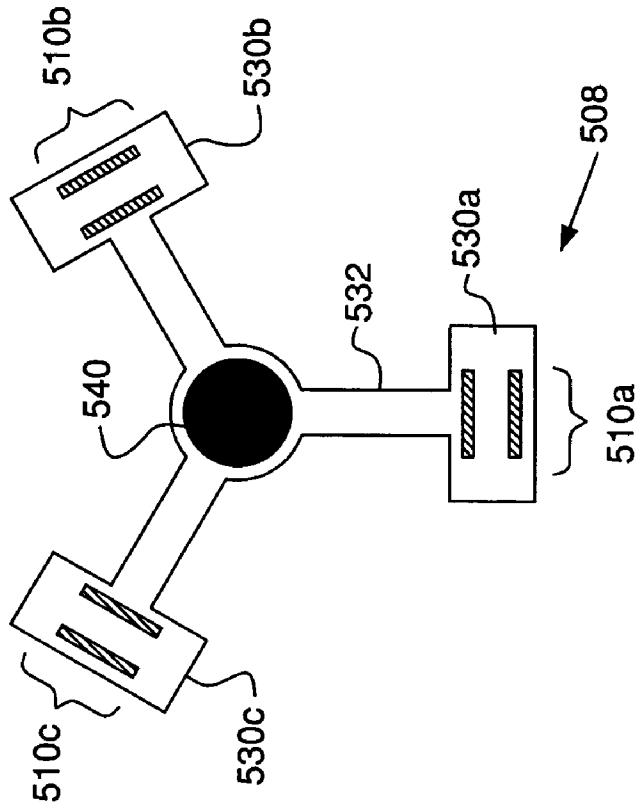

FIG. 5

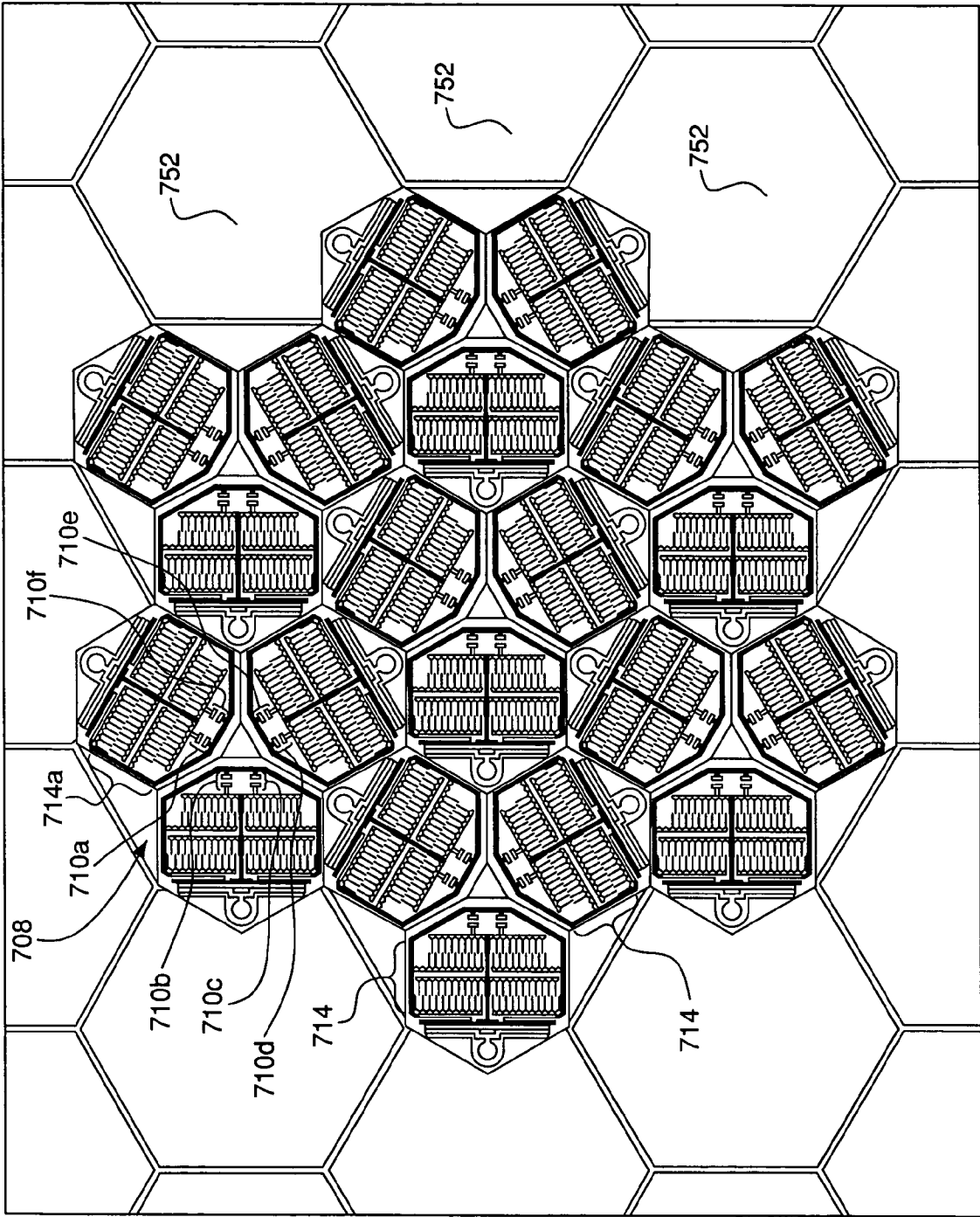

FIG. 7

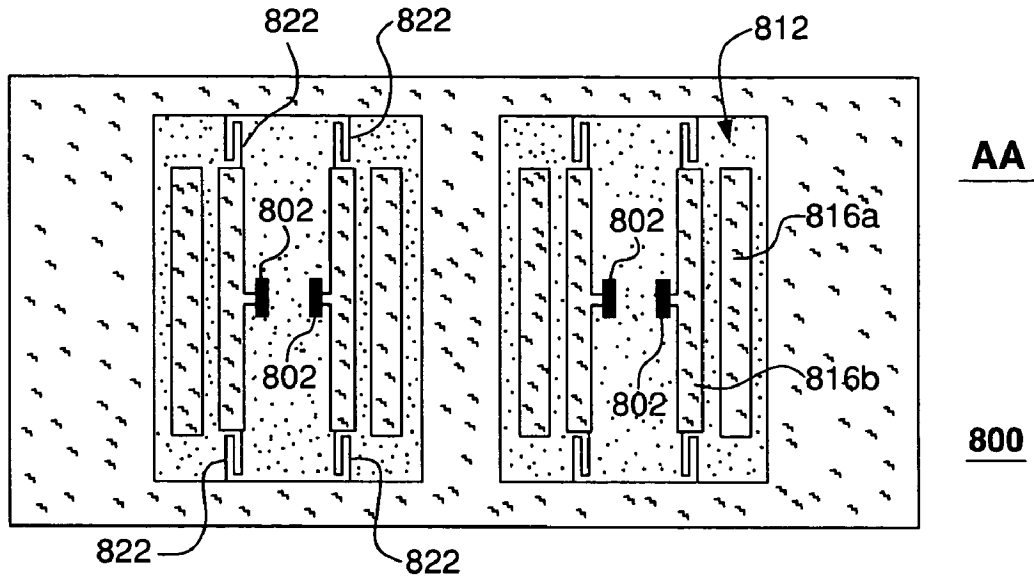

FIG. 8B

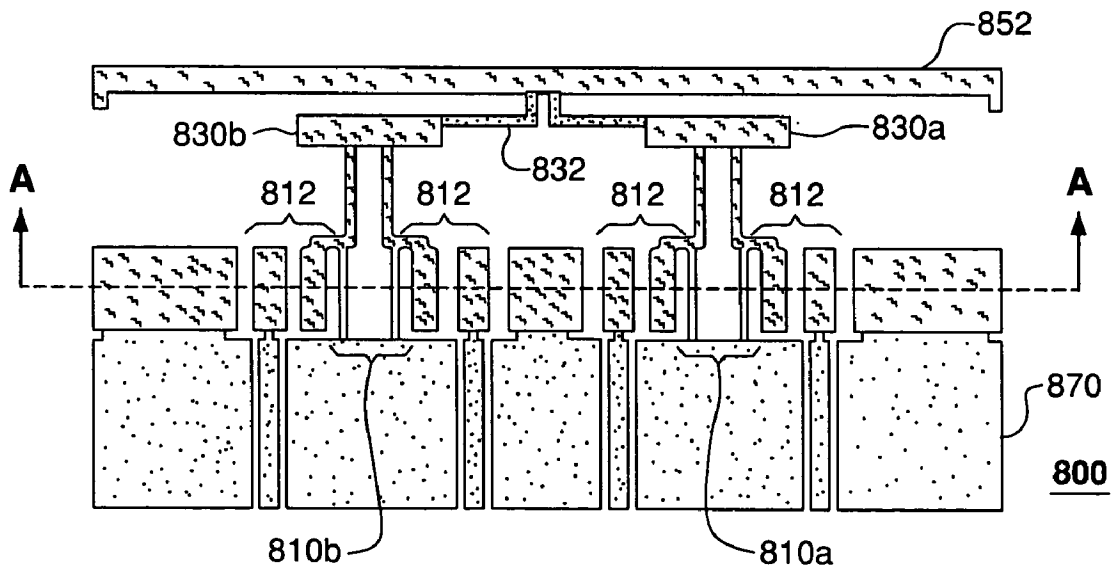

FIG. 8A

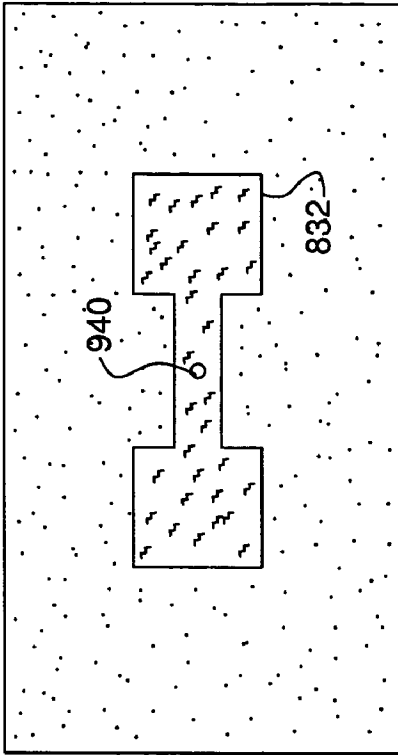

FIG. 9D

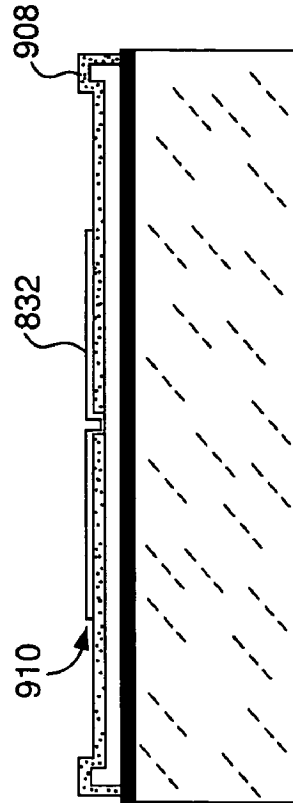

FIG. 9C

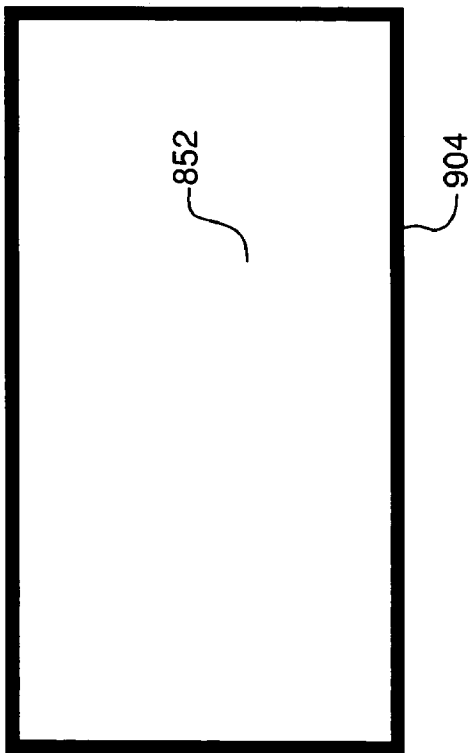

FIG. 9B

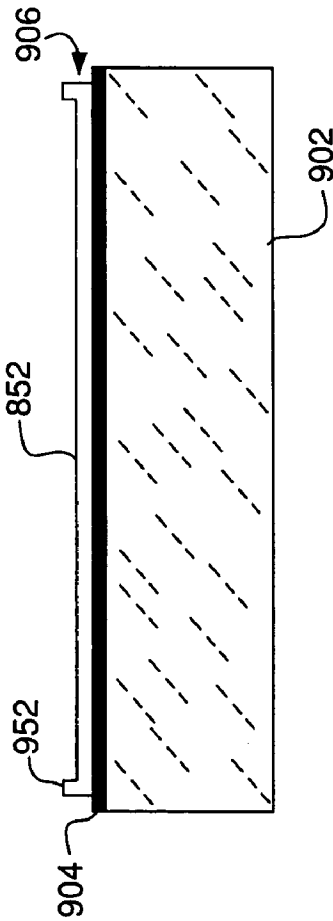

FIG. 9A

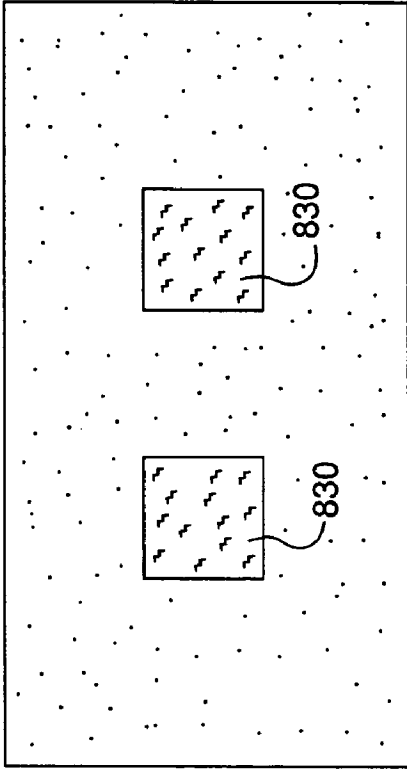

FIG. 9H

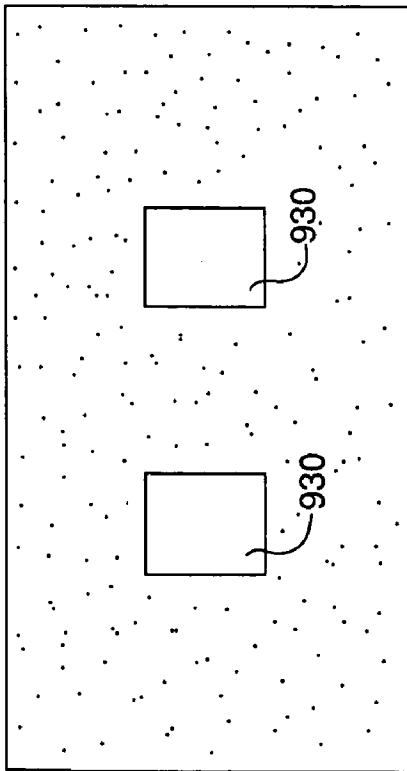

FIG. 9F

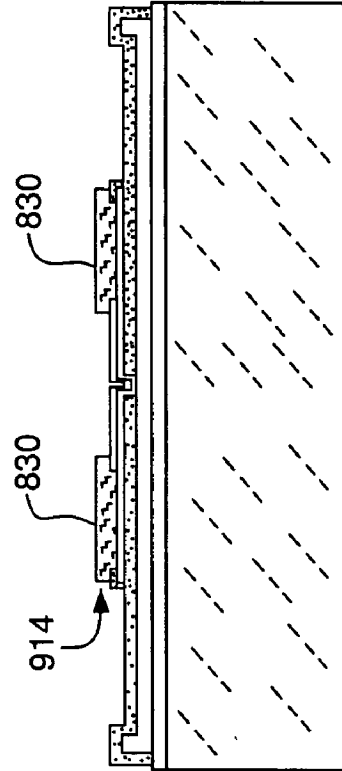

FIG. 9G

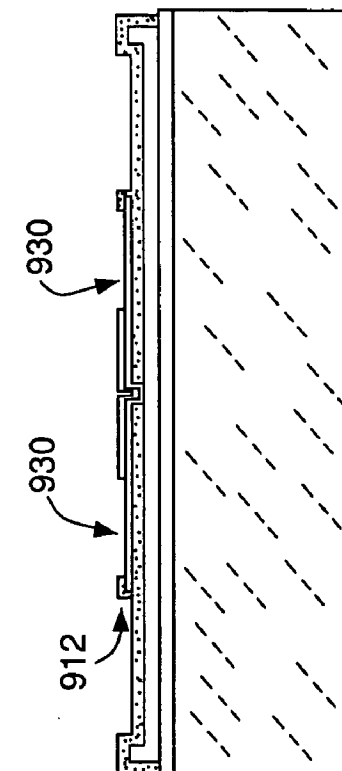

FIG. 9E

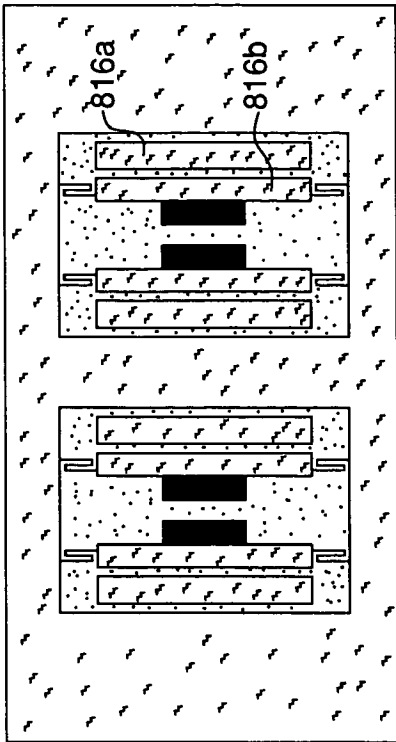

FIG. 9L

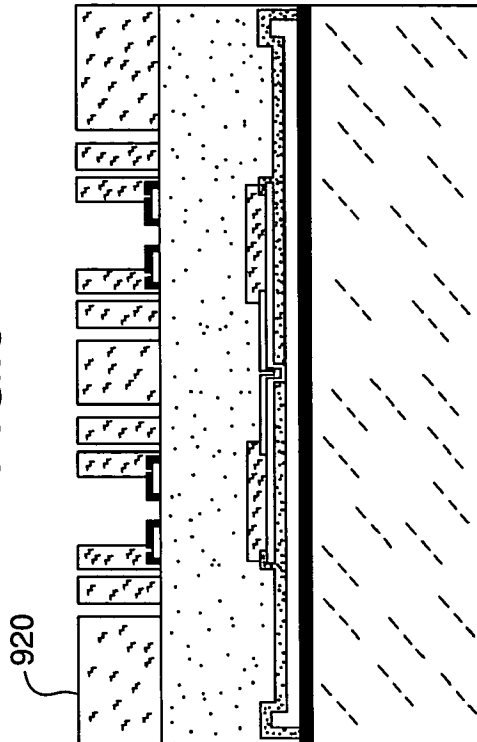

FIG. 9K

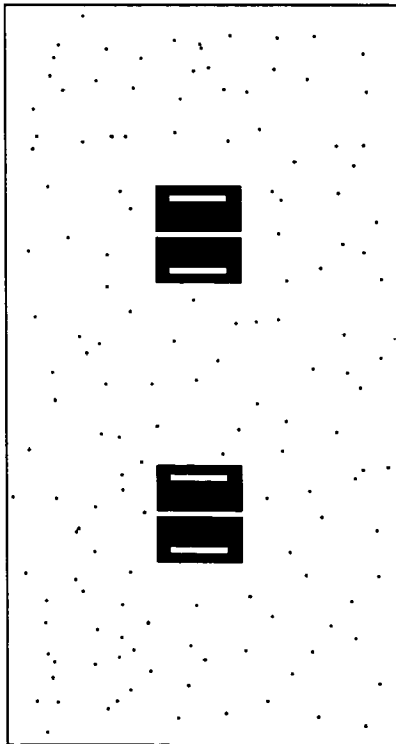

FIG. 9J

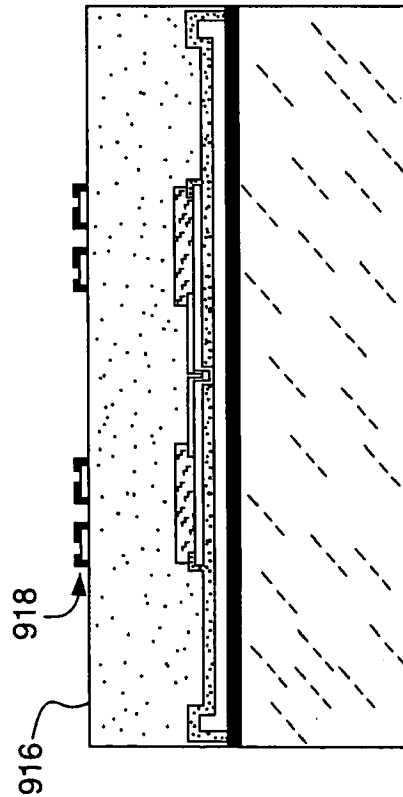

FIG. 9I

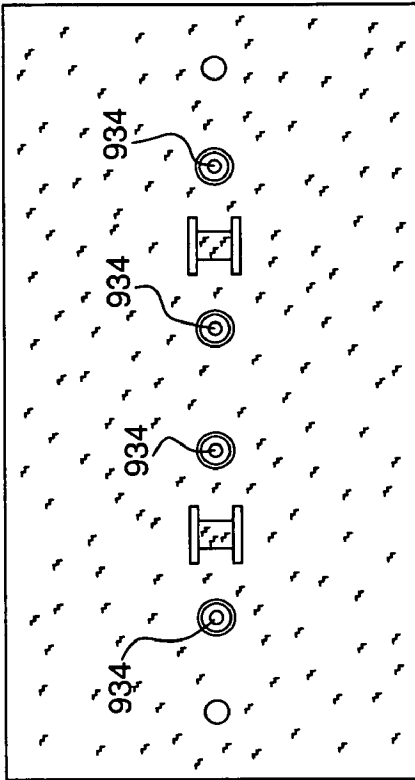

FIG. 9P

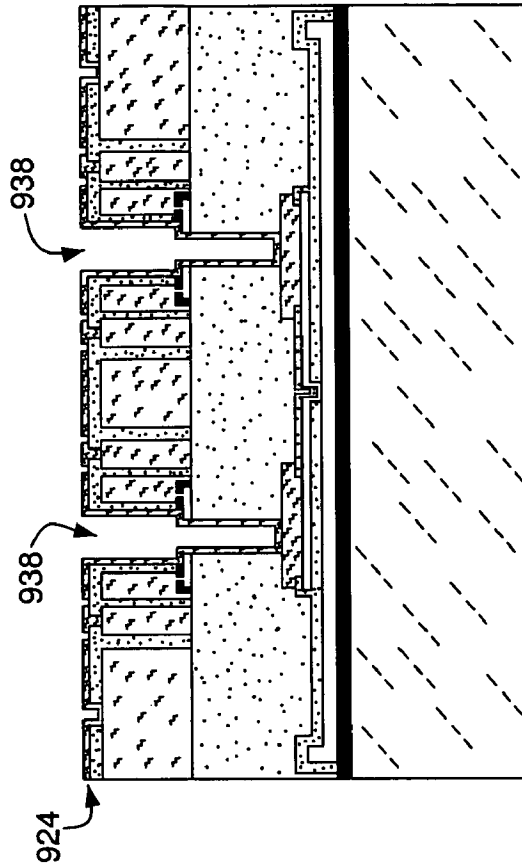

FIG. 90

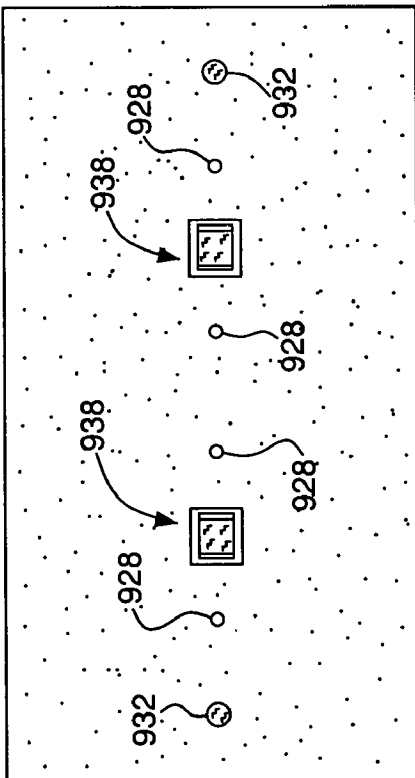

FIG. 9N

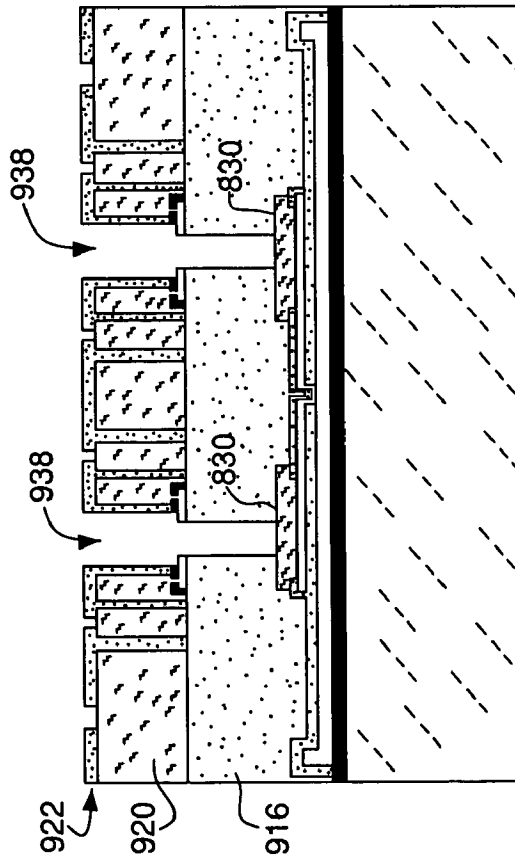

FIG. 9M

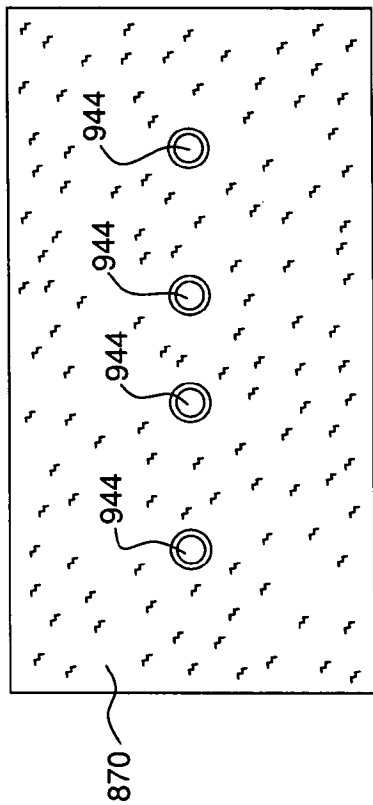

FIG. 9R

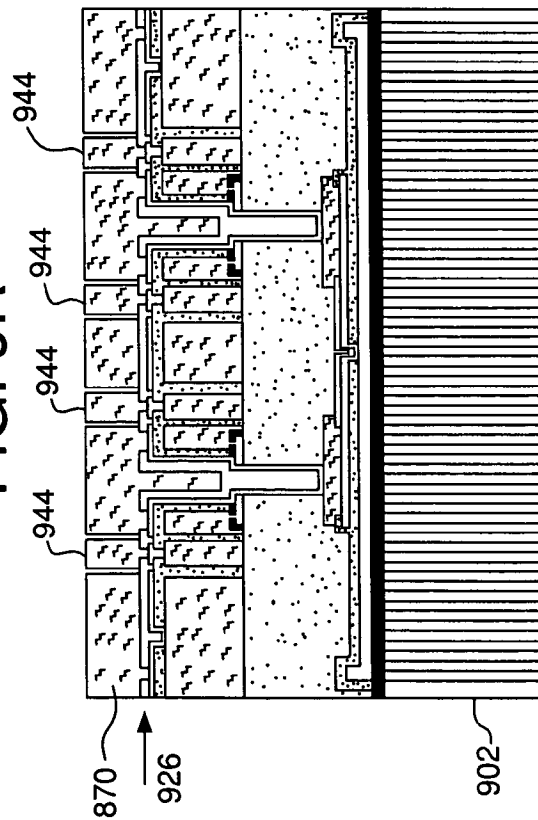

FIG. 9Q

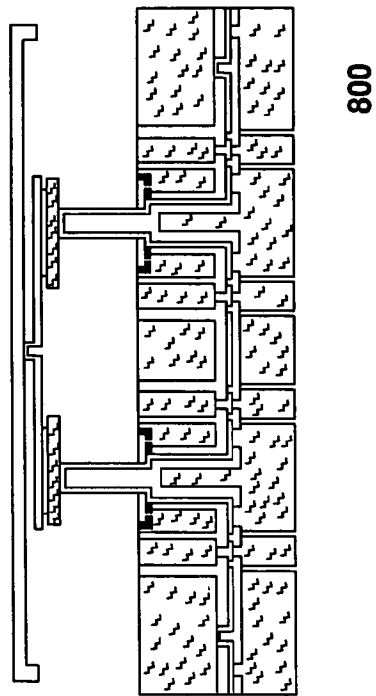

FIG. 9S

1

MEMS ACTUATOR FOR PISTON AND TILT MOTION

BACKGROUND OF THE INVENTION

1. Field of the Invention

The present invention relates to adaptive optics and, more specifically, to micro-electromechanical systems (MEMS) for implementing adaptive optics.

2. Description of the Related Art

Adaptive optics is a field of optics dedicated to the improvement of optical signals using information about signal distortions introduced by the environment in which the optical signals propagate. An excellent introductory text on the subject is given in "Principles of Adaptive Optics" by R. K. Tyson, Academic Press, San Diego, 1991, the teachings of which are incorporated herein by reference.

A representative example of an adaptive optical element is a deformable mirror driven by a wavefront sensor and configured to compensate for atmospheric distortions that affect telescope images. Small naturally occurring variations in temperature ($\sim 1^\circ$ C.) in the atmosphere cause random turbulent motion of the air and give rise to changes in the atmospheric density and, hence, to the index of refraction. The cumulative effect of these changes along the beam propagation path may lead to beam wandering and spreading and to beam intensity fluctuations, each of which degrades image quality. The wavefront sensor is a device that measures the distortions introduced in the atmosphere and generates feedback for the deformable mirror. Based on the feedback, the mirror is deformed such that the beam distortions are significantly reduced, thus improving the image quality.

U.S. Pat. No. 6,384,952, the teachings of which are incorporated herein by reference, discloses a representative prior-art device having a deformable membrane mirror connected to a plurality of actuators. To enable the membrane deformations, each actuator has two interleaved comb-shaped portions connected between the membrane and a substrate and offset with respect to each other in the direction perpendicular to the substrate. During the device fabrication process, the offset comb-shaped portions are typically formed in different layers of a layered wafer, which may result in certain wafer processing problems. For example, it may be relatively difficult to achieve proper alignment of the interleaved structures of said comb-shaped portions with respect to each other because different layers are processed during different fabrication steps using different lithographic masks.

SUMMARY OF THE INVENTION

Problems in the prior art are addressed, in accordance with the principles of the present invention, by a MEMS device, in which the distance between the ends of a flexible beam, at least one of which is coupled to a movable bar, may be changed so as to move the movable bar with respect to a substrate of the MEMS device. A motion drive may be employed to change the distance between the ends of the flexible beam. The motion drive may have a movable portion adapted to move substantially parallel to the substrate, while the flexible beam is adapted to transfer the motion to the movable bar such that its offset distance from the substrate is changed. Advantageously, in such an arrangement, due to this motion transfer, MEMS devices of the invention can employ planar motion drives and, yet, produce out-of-plane motion for the movable bar. During the

2

device fabrication process, such planar motion drives can be formed using a single layer of a layered wafer, which alleviates stringent precision requirements for the alignment of lithographic masks corresponding to different wafer layers.

In one embodiment, the MEMS device has a spring structure formed by two flexible beams attached between the substrate and a movable bar. When non-end (intermediate) sections of the beams are pulled in opposite directions, the beams pull the movable bar toward the substrate, thereby transforming in-plane motion of the non-end sections into out-of-plane motion of the movable bar. When the non-end sections are displaced symmetrically, the movable bar translates toward or away from the substrate. Alternatively, when the non-end sections are displaced non-symmetrically, the movable bar rotates with respect to the substrate.

In another embodiment, the MEMS device has a motion drive with two comb-shaped portions. Each of the comb-shaped portions is (i) attached to a corresponding flexible beam, (ii) interleaved with the other comb-shaped portion, and (iii) adapted to move with respect to the substrate and that other comb-shaped portion. When a voltage differential is applied between the comb-shaped portions, they move substantially parallel to the substrate, thereby changing the shape of the beams and translating/rotating the movable bar. Advantageously, such a motion drive can be positioned at one side of the spring structure and, yet, provide a symmetric deformation of the flexible beams.

BRIEF DESCRIPTION OF THE DRAWINGS

FIG. 1 shows a side cross-sectional view of a representative prior-art device having a deformable membrane;

FIG. 2 shows a side cross-sectional view of a MEMS device having a deformable membrane according to one embodiment of the present invention;

FIG. 3 shows a side cross-sectional view of a MEMS device having a segmented plate according to another embodiment of the present invention;

FIG. 4 shows a side view cross-sectional of a spring structure arrangement that can be used in a device similar to the device of FIG. 3 according to one embodiment of the present invention;

FIG. 5 shows a top view of a spring structure arrangement that can be used in a device similar to the device of FIG. 3 according to another embodiment of the present invention;

FIG. 6 shows a top view of a motion drive that can be used with the spring structure arrangement of FIG. 5 according to one embodiment of the present invention;

FIG. 7 shows a cutout top view of a MEMS device having a segmented plate according to yet another embodiment of the present invention;

FIGS. 8A–B show side and top cross-sectional views, respectively, of a MEMS device according to yet another embodiment of the present invention; and

FIGS. 9A–S illustrate representative fabrication steps of the device shown in FIG. 8 according to one embodiment of the invention.

DETAILED DESCRIPTION

Reference herein to "one embodiment" or "an embodiment" means that a particular feature, structure, or characteristic described in connection with the embodiment can be included in at least one embodiment of the invention. The appearances of the phrase "in one embodiment" in various places in the specification are not necessarily all referring to

3

the same embodiment, nor are separate or alternative embodiments mutually exclusive of other embodiments.

FIG. 1 shows a side view of a representative prior-art device **100** disclosed in U.S. Pat. No. 6,384,952. Device **100** has a deformable membrane **150** connected to a plurality of actuators **190** supported on a substrate **170**. Only two actuators **190a-b** of the plurality are shown in FIG. 1. Each actuator **190** has (i) a stator **110** attached to substrate **170** and (ii) a slider **120** supported on the substrate by two anchors **180** and a spring **160**. To transfer motion of slider **120** to membrane **150**, device **100** has a pole **140** attached between the membrane and a slider bar **130**. When a voltage differential is applied between stator **110** and slider **120** of actuator **190**, the slider pulls membrane **150** toward substrate **170**, e.g., as shown in actuator **190a**. When the voltage differential is removed, the spring force of spring **160** returns slider **120** into the initial position, e.g., as shown in actuator **190b**. When different actuators **190** are appropriately biased to produce different displacements, membrane **150** is deformed into a desirable shape, e.g., corresponding to wavefront distortions.

One problem with device **100** is related to its fabrication. More specifically, since stator **110** and slider **120** of actuator **190** are (vertically) offset with respect to each other, they are formed in different layers of a layered wafer typically used in the device fabrication process. Because different layers are processed during different fabrication steps using different lithographic masks, it is relatively difficult to achieve proper alignment of the interleaved comb structures of stator **110** and slider **120** with respect to each other. This difficulty arises primarily from the underlying requirement to overlay the lithographic masks with sub-micron precision.

FIG. 2 shows a side cross-sectional view of a MEMS device **200** according to one embodiment of the present invention. Device **200** has a deformable membrane **250** connected to a plurality of actuators **290** supported on a substrate **270**. Each actuator **290**, only two of which (actuators **290a-b**) are shown in FIG. 2, has a spring structure **210** including two deformable beams **202a-b** attached between substrate **270** and a slider bar **230**. To transfer motion of slider bar **230** to membrane **250**, device **200** has a pole **240** attached between the membrane and the slider bar. Beams **202a-b** are flexible and can be bent, e.g., as shown in actuator **290a**. When center portions of beams **202a-b** are pulled in opposite directions, slider bar **230** is pulled toward substrate **270**, thereby displacing the corresponding portion of membrane **250**.

To flex beams **202a-b**, actuator **290** has two motion drives **212a-b**, each connected between the center section of the corresponding beam **202** and an anchor **280**. In one embodiment, each drive **212** is a comb drive having two interleaved comb-shaped portions adapted to laterally displace the center section of beam **202**, when a voltage differential is applied between said two portions. When the voltage differential is removed, the spring forces generated by deformed beam **202** return drive **212** into the initial state. Biased and non-biased states of drives **212** are illustrated in actuators **290a** and **290b**, respectively.

Unlike actuator **190** of prior-art device **100** (FIG. 1) whose interleaved comb-shaped portions (i.e., stator **110** and slider **120**) are offset from substrate **170** by different distances, actuator **290** of device **200** has drives **212**, each of which has a planar structure parallel to substrate **270**. Due to the use of spring structure **210**, actuator **290** transforms in-plane motion of drives **212** into out-of-plane motion of slider bar **230**. Advantageously, during the device fabrication process, planar drives **212** can be formed using a single

4

layer of a layered wafer and, consequently, the interleaved comb-shaped portions of drives **212** can be mapped onto that single layer using a single lithographic mask. This alleviates stringent precision requirements for the alignment of lithographic masks corresponding to different wafer layers.

FIG. 3 shows a side cross-sectional view of a MEMS device **300** according to another embodiment of the present invention. Device **300** is similar to device **200** of FIG. 2 with one difference between said devices being that device **300** has a segmented plate **350** instead of deformable membrane **250**. Segmented plate **350** has a plurality of segments **352**, only two of which (segments **352a-b**) are shown in FIG. 3. For each segment **352**, device **300** has a corresponding actuator **290** adapted to translate and/or tilt the segment. For example, when beams **202a-b** of actuator **290** are deformed symmetrically, the corresponding segment **352** is translated via piston-like motion as shown with segment **352a**. Alternatively, when one beam **202** is deformed while the other beam remains substantially non-deformed, the corresponding segment **352** is rotated as shown with segment **352b**. One skilled in the art will appreciate that non-symmetric deformation of both beams **202** will result in simultaneous translation and rotation of the corresponding segment **352**.

FIG. 4 shows a side cross-sectional view of a spring structure arrangement **408** that can be used in a device similar to device **300** according to one embodiment of the present invention. More specifically, arrangement **408** has two spring structures **410a-b** per segment. Slider bars **430a-b** corresponding to spring structures **410a-b**, respectively, are connected by a deformable beam **432**, on which segment **452** is mounted using a pole **440**. One purpose of having two spring structures instead of one is the ability to tilt and/or translate segment **452** using only symmetric beam deformations within each spring structure. For example, when the deformable beams of spring structure **410a** are symmetrically deformed while the deformable beams of spring structure **410b** remain substantially undeformed as shown in FIG. 4, segment **452** is rotated by angle θ and a center point of the segment is translated toward substrate **270** by distance Δy .

FIG. 5 shows a top view of a spring structure arrangement **508** that can be used in a device similar to device **300** according to another embodiment of the present invention. Arrangement **508** is similar to arrangement **408** (FIG. 4). However, arrangement **508** has three spring structures **510a-c** per segment instead of two such springs in arrangement **408**. Slider bars **530a-c** corresponding to spring structures **510a-c** are connected by a trampoline beam structure **532**, on which a segment (not shown in FIG. 5) of the corresponding segmented plate is mounted using a pole **540**. One purpose of having three spring structures per segment instead of two is the added capability to tilt the segment in any desired direction.

FIG. 6 shows a comb drive **614** that can be used with spring structure arrangement **508** of FIG. 5 according to one embodiment of the present invention. More specifically, drive **614** has two movable comb-shaped portions **616a** and **616b** mounted on a movable support frame **604** and a movable support shaft **606**, respectively. Frame **604** is connected, at one side, to deformable beam **602a** of a spring structure **610** (extending perpendicular to the plane of FIG. 6) and, at the other side, via springs **622a**, to anchors **680a**. Similarly, shaft **606** is connected, at one end, to deformable beam **602b** of spring structure **610** and, at the other end, via spring **622b**, to an anchor **680b**. Anchors **680a-b** are similar to anchors **280** of device **300** (FIG. 3) and are attached to the substrate on which drive **614** is mounted.

One novel structural feature of drive **614** is that both comb-shaped portions **616a–b** of said drive are movable with respect to the substrate. In contrast, a prior-art comb drive typically has only one movable portion, while the other portion is fixedly connected to the substrate (see, e.g., FIG. **1**). Due to this novel feature, drive **614** can be placed at one side of spring structure **610** as shown in FIG. **6** and, yet, provide a symmetric deformation of that spring structure similar to one shown in spring structure **410a** of FIG. **4**. For example, when a voltage differential is applied between portions **616a–b** of drive **614**, an attractive electrostatic force causes these portions to move toward each other, such that each portion also moves with respect to the substrate, thereby deforming beams **602a–b** and springs **622a–b**. The elastic spring force generated by the deformation of beams **602a–b** and springs **622a–b** provides the counterbalance force to the electrostatic force. However, springs **622a–b** are designed to be relatively soft, such that almost the entire counterbalance force comes from the deformation of beams **602a–b**. When beams **602a–b** have substantially identical stiffness, action of the electrostatic force will cause equal displacements of the center sections of the beams in opposite directions, thereby producing a symmetric deformation of spring structure **610**. Alternatively, when beams **602a–b** have different stiffness values, action of the electrostatic force will cause different displacements of the center sections of the beams, thereby producing a non-symmetric deformation of spring structure **610**.

FIG. **7** shows a cutout top view of a MEMS device **700** according to yet another embodiment of the present invention. Device **700** is analogous to device **300** (FIG. **3**) and has a segmented plate having a plurality of segments **752**. For each segment **752**, device **700** has a spring structure arrangement **708** that is analogous to arrangement **508** of FIG. **5**. However, one difference between arrangement **708** and arrangement **508** is that the former has six spring structures **710a–f** grouped in three pairs instead of three individual spring structures **510a–c** in the latter. Each pair of spring structures **710** is connected to a corresponding comb drive **714**, which is similar to comb drive **614** of FIG. **6**. For example, spring structures **710a** and **710f** are connected to comb drive **714a**. One purpose of having additional spring structures in arrangement **708** is, for each comb-shaped portion of drive **714**, to have two relatively far-separated points to which the counterbalance spring forces generated by the deformed beams are applied. This enhances stability of comb drive **714** with respect to undesirable lateral displacements of the comb-shaped portions.

FIGS. **8A–B** show side and top cross-sectional views, respectively, of a MEMS device **800** according to yet another embodiment of the present invention. Device **800** is analogous to device **300** (FIG. **3**) and has a movable segment **852** and two spring structures **810a–b** arranged similar to spring structures **410a–b** of FIG. **4**. Slider bars **830a–b** corresponding to spring structures **810a–b** are connected by a beam structure **832**, on which segment **852** is mounted. For each deformable beam **802** of spring structures **810a–b**, device **800** has an in-plane drive **812** comprising (i) a stationary portion **816a** fixedly connected to a substrate **870** and (ii) a movable portion **816b** connected to the center section of beam **802** and suspended over the substrate by two serpentine springs **822**. Each drive **812** can be individually biased to produce a desired deflection of the corresponding beam **802** to translate and/or rotate segment **852**.

FIGS. **9A–S** schematically illustrate representative fabrication steps of device **800** according to one embodiment of the invention. More specifically, FIGS. **9A**, **9C**, **9E**, **9G**, **9I**,

9K, **9M**, **9O**, **9Q**, and **9S** show side views of device **800** during those fabrication steps, whereas FIGS. **9B**, **9D**, **9F**, **9H**, **9J**, **9L**, **9N**, **9P**, and **9R** show the corresponding top views of the device. The side and top views shown in FIG. **9** correspond to the side and top views shown in FIG. **8**.

Referring to FIGS. **9A–B**, in one embodiment, fabrication of device **800** begins with a silicon-on-insulator (SOI) wafer having (i) two silicon layers, i.e., a substrate layer **902** and an overlayer **906**, and (ii) a silicon oxide layer **904** located between overlayer **906** and substrate layer **902**. Segment **852** is defined in overlayer **906** using reactive etching, which stops at the silicon oxide layer. A timed etch of overlayer **906** can be used to thin the inner portion of segment **852** and create stiffening ribs **952** around the segment perimeter.

Referring to FIGS. **9C–D**, first, a thin (e.g., $2\ \mu\text{m}$) silicon oxide layer **908** is deposited over segment **852**. Second, layer **908** is patterned and etched to form an opening **940** for a pole connecting segment **852** to deformable beam structure **832** (not formed yet, see FIG. **8A**). Then, a thin (e.g., $0.5\ \mu\text{m}$) poly-silicon layer **910** is deposited over layer **908**. Finally, layer **910** is patterned and etched to form beam structure **832**.

Referring to FIGS. **9E–F**, first, a thin (e.g., $1\ \mu\text{m}$) silicon oxide layer **912** is deposited over the structure of FIGS. **9C–D**. Then, layer **912** is patterned and etched to form openings **930** for slider bars **830** (not formed yet, see FIG. **8A**).

Referring to FIGS. **9G–H**, first, a thin (e.g., $2\ \mu\text{m}$) poly-silicon layer **914** is deposited over the structure of FIGS. **9E–F**. Then, layer **914** is patterned and etched to form slider bars **830** (see FIG. **8A**).

Referring to FIGS. **9I–J**, first, a thick (e.g., $10\ \mu\text{m}$) silicon oxide layer **916** is deposited over the structure of FIGS. **9G–H**. The thickness of layer **916** determines the vertical offset of segment **852** with respect to the driver layer and, therefore, the maximum possible tilt angle of the segment (see also FIG. **8A**). Second, a thin (e.g., $1\ \mu\text{m}$) poly-silicon layer **918** is deposited over layer **916**. Then, layer **918** is patterned and etched to create the structures that will tie beams **802** to drives **812** (not formed yet, see FIG. **8A**). Finally, a thin layer of slow-etching thermal silicon oxide is formed over the tying structures. This layer is patterned and etched to provide an appropriate etch stop for the subsequent processing steps.

Referring to FIGS. **9K–L**, first, a relatively thick (e.g., $5\ \mu\text{m}$) poly-silicon layer **920** is deposited over the structure of FIGS. **9I–J**. Then, layer **920** is patterned and etched to form drivers **812** and serpentine springs **822** (see also FIG. **8B**).

Referring to FIGS. **9M–N**, first, a thin (e.g., $1\ \mu\text{m}$) silicon oxide layer **922** is deposited over the structure of FIGS. **9K–L**. Then, layer **922** is patterned and etched to form openings **928** and **932** for future via structures. In particular, the via structures corresponding to openings **928** provide electrical contact of portions **816a** (FIGS. **8B** and **9L**) with the corresponding bias electrodes (not formed yet), and the via structures corresponding to openings **932** provide electrical contact of layer **920** with substrate layer **870** (not formed yet). In addition, openings **938** are formed in layers **922**, **920**, and **916** to expose slider bars **830**.

Referring to FIGS. **9O–P**, first, a thin (e.g., $0.5\ \mu\text{m}$) adaptive poly-silicon layer **924** is deposited over the structure of FIGS. **9M–N**. Layer **924** covers the walls of openings **938**. Then, layer **924** is patterned and etched to create contact pads **934** for the bias electrodes and to form deformable beams **802** of spring structures **810**.

Referring to FIGS. **9Q–R**, first, a thin (e.g., $2\ \mu\text{m}$) silicon oxide layer **926** is deposited over the structure of FIGS.

90–P such that it partially fills openings 938. Layer 926 is then patterned and etched to provide access to contact pads 934 and the via structures of openings 932. Second, thick (e.g., 10 μm) silicon substrate layer 870 is deposited over layer 926. Substrate layer 870 is patterned and etched to create electrodes 944 corresponding to portions 816a of drivers 812, which electrodes are electrically isolated from the rest of the substrate layer by the grooves surrounding each electrode. Then, substrate layer 902 is etched as shown in FIG. 9Q to create a removable cradle.

Finally, referring to FIG. 9S, exposed portions of various oxide layers are removed (e.g., etched away) to release the movable parts of device 800 and expose segment 852. Note that the view shown in FIG. 9S is flipped with respect to the view shown in FIG. 9Q. A thin layer of metal, e.g., gold, is optionally deposited over the outer surface of segment 852 for better reflectivity and over electrodes 944 for better electrical contact with wire terminals (not shown).

Different etching techniques may be used to fabricate device 800 from the initial SOI wafer. It is known that silicon etches significantly faster than silicon oxide using, e.g., selective reactive ion etching (RIE). Similarly, silicon oxide etches significantly faster than silicon using, e.g., fluorine-based etchants. Additional layers of material (e.g., layers 908–926) may be deposited using, e.g., chemical vapor deposition. Various parts of device 800 may be mapped onto the corresponding layers using lithography. Additional description of various fabrication steps may be found in U.S. Pat. Nos. 6,201,631, 5,629,790, and 5,501,893, the teachings of which are incorporated herein by reference.

While this invention has been described with reference to illustrative embodiments, this description is not intended to be construed in a limiting sense. Various modifications of the described embodiments, as well as other embodiments of the invention, which are apparent to persons skilled in the art to which the invention pertains are deemed to lie within the principle and scope of the invention as expressed in the following claims.

Although fabrication of MEMS devices of the invention has been described in the context of using silicon/silicon oxide SOI wafers, other suitable materials, such as germanium-compensated silicon, may similarly be used. The materials may be appropriately doped as known in the art. Various surfaces may be modified, e.g., by metal deposition for enhanced reflectivity and/or electrical conductivity or by ion implantation for enhanced mechanical strength. Differently shaped membranes, plates, segments, beams, drives, actuators, and/or electrodes may be implemented without departing from the scope and principle of the invention. Springs may have different shapes and sizes, where the term “spring” refers in general to any suitable elastic structure that can recover its original shape after being distorted. A MEMS device of the invention may be configured to have one or more of its springs in a deformed (loaded or stretched) state when the corresponding one or more deformable plates are at their initial prescribed position or at any position within the available position range. Various MEMS devices of the invention may be arrayed as necessary and/or apparent to a person skilled in the art.

I claim:

1. A MEMS device, comprising:

a first flexible beam coupled at a first end to a substrate and at a second end to a movable plate positioned at an offset distance from the substrate, said first and second ends separated by a prescribed distance at a rest position; and

one or more motion drives adapted to change the distance between the first and second ends from said prescribed distance, thereby changing the offset distance.

2. The device of claim 1, wherein:

the one or more motion drives have one or more movable portions supported on the substrate and mechanically coupled to the first flexible beam, said portions adapted to move substantially along a plane parallel to the substrate; and

the first flexible beam is adapted to transfer motion from the one or more movable portions to the movable plate such that the offset distance is changed.

3. The device of claim 1, wherein the prescribed distance corresponds to a loaded state of the first flexible beam.

4. The device of claim 1, wherein the device has a second flexible beam coupled to the substrate, the movable plate, and the one or more motion drives.

5. The device of claim 4, wherein the one or more motion drives are adapted to bend the flexible beams, wherein, when non-end sections of the first and second flexible beams move in opposite directions, the offset distance is changed.

6. The device of claim 5, wherein:

the one or more motion drives are adapted to move the non-end sections of the first and second flexible beams in the opposite directions by substantially equal distances; and

the movable plate is adapted to translate with respect to the substrate.

7. The device of claim 5, wherein:

a first motion drive is adapted to bend the first flexible beam;

a second motion drive is adapted to bend the second flexible beam;

bending of the first flexible beam and bending of the second flexible beam are substantially independent of each other; and

the movable plate is adapted to rotate with respect to the substrate.

8. The device of claim 5, wherein the one or more motion drives include a motion drive having (i) a first portion fixedly connected to the substrate and (ii) a second portion attached to the non-end section of the corresponding flexible beam, wherein, when a voltage differential is applied between the first and second portions, the second portion moves with respect to the substrate, thereby bending said flexible beam.

9. The device of claim 1, wherein the plate has a reflective surface.

10. The device of claim 1, comprising two or more spring structures, each spring structure having two flexible beams connected to the substrate, wherein:

the two spring structures are connected by a beam structure; and

the plate is mounted on the beam structure.

11. The device of claim 1, wherein the plate is a segment of a segmented plate.

12. The device of claim 11, wherein each segment is adapted to move substantially independent of every other segment.

13. The device of claim 1, wherein:

the plate comprises a deformable membrane; and motion generated by the one or more motion drives deforms the membrane.

14. The device of claim 1, wherein the one or more motion drives include a motion drive having first and second movable portions, each adapted to move with respect to the substrate and the other movable portion.

- 15.** A MEMS device, comprising:
 a spring structure coupled between a substrate and a
 movable plate positioned at an offset distance from the
 substrate; and
 one or more motion drives having one or more movable
 portions supported on the substrate and mechanically
 coupled to the spring structure, wherein:
 the one or more movable portions are adapted to move
 substantially along a plane parallel to the substrate; and
 the spring structure is adapted to transfer motion of the
 one or more movable portions to the movable plate
 such that the offset distance is changed.
- 16.** The device of claim **15**, wherein:
 the spring structure has one or more flexible beams, each
 coupled to at least two of: (i) the substrate, (ii) the
 movable plate, and (iii) one of the motion drives; and
 the one or more motion drives are adapted to bend the one
 or more flexible beams to change the offset distance.
- 17.** The device of claim **16**, wherein the one or more
 motion drives include a motion drive having (i) a first
 portion fixedly connected to the substrate and (ii) a second
 portion attached to the corresponding flexible beam,
 wherein, when a voltage differential is applied between the
 first and second portions, the second portion moves with
 respect to the substrate, thereby bending said flexible beam.
- 18.** The device of claim **16**, wherein:
 the one or more motion drives include a motion drive
 having first and second movable portions, each adapted
 to move with respect to the substrate and the other
 movable portion;
 the first movable portion is attached to a first flexible
 beam; and
 the second movable portion is attached to a second
 flexible beam, wherein, when a voltage differential is
 applied between the first and second portions, the first
 and second portions move with respect to the substrate
 and each other, thereby bending the first and second
 flexible beams.
- 19.** The device of claim **15**, wherein the one or more
 motion drives include a motion drive having first and second
 movable portions, each adapted to move with respect to the
 substrate and the other movable portion.
- 20.** The device of claim **15**, wherein:
 the one or more motion drives include a planar motion
 drive; and
 the device is fabricated using a layered wafer such that the
 planar motion drive is fabricated from a single layer of
 said wafer.
- 21.** A MEMS device, comprising a motion drive sup-
 ported on a substrate and having first and second movable
 portions, wherein, when a voltage differential is applied
 between the first and second portions, the first and second
 portions move with respect to the substrate and each other.
- 22.** The device of claim **21**, further comprising a spring
 structure having first and second flexible beams coupled

- between the substrate and a movable plate, wherein the
 motion drive is adapted to bend the flexible beams.
- 23.** The device of claim **22**, wherein:
 the first movable portion is coupled to a non-end section
 of the first flexible beam; and
 the second movable portion is coupled to a non-end
 section of the second flexible beam, wherein, when the
 non-end sections of the first and second flexible beams
 move in opposite directions substantially parallel to the
 substrate, the movable plate moves with respect to the
 substrate.
- 24.** The device of claim **23**, wherein, when the voltage
 differential is applied between the first and second portions,
 said non-end sections of the first and second flexible beams
 move in opposite directions by substantially equal distances
 and the movable plate translates toward or away from the
 substrate.
- 25.** The device of claim **21**, wherein:
 the motion drive is a planar motion drive; and
 the first and second movable portions are adapted to move
 substantially along a plane parallel to the substrate.
- 26.** The device of claim **25**, wherein the device is fabri-
 cated using a layered wafer and the motion drive is fabri-
 cated from a single layer of said wafer.
- 27.** A method of operating a MEMS device, the method
 comprising:
 changing the distance between first and second ends of a
 flexible beam from a prescribed distance, wherein:
 the flexible beam is coupled at the first end to a
 substrate and at the second end to a movable plate
 positioned at an offset distance from the substrate,
 said first and second ends separated by the prescribed
 distance at a rest position; and
 said change from the prescribed distance causes a
 change of the offset distance.
- 28.** The method of claim **27**, further comprising moving
 a non-end section of the flexible beam substantially along a
 plane parallel to the substrate, wherein the flexible beam is
 adapted to transfer said motion to the movable plate to
 change the offset distance.
- 29.** A MEMS device, comprising:
 flexible means for supporting a movable plate positioned
 at an offset distance from a substrate, said flexible
 means having a first end coupled to the substrate and a
 second end coupled to the movable plate; and
 means for changing the distance between the first and
 second ends, wherein:
 the first and second ends are separated by a prescribed
 distance at a rest position; and
 change of the distance between the first and second
 ends from the prescribed distance causes a change of
 the offset distance.